



© 2008
Dallas, Texas, USA

506158-01
KAZ # C.6148
08/2008
Supersedes 505,279M

HUMIDIFIERS

HCWP2-18 & HCWP2-18A HUMIDIFIERS

INSTALLATION INSTRUCTIONS FOR HCWP2-18 & HCWP2-18A HUMIDIFIER

Shipping & Packing List

Package 1 of 1 contains the following:

- 1 - Assembled humidifier
- 1 - Humidistat with mounting plates
- 1 - Bag assembly with screws and saddle valve
- 1 - Literature packet
- 1 - Mounting template

Shipping Damage

Check equipment for shipping damage. If damage is found, immediately contact last carrier.

Specifications -- Power Humidifiers -- HCWP2-18 & HCWP2-18A

- Unit dimensions: 15-15/16" W x 16 3/32" H x 10 1/8" D
- Plenum opening: 14-3/4" W X 14-1/2" H
- Water feed rate: 3 gph
- Electrical data: 120V, 60Hz, 0.5 AMP

General Information

⚠ WARNING

Risk of property damage, injury, or death.

Installation and service must be performed by a qualified installer or service agency.

Installation must conform to all local, state and federal codes.

⚠ CAUTION

As with any mechanical equipment, personal injury can result from contact with sharp sheet metal edges. Be careful when you handle this equipment.

⚠ CAUTION

Risk of scalding.

Water temperature over 125°F can cause severe burns and scalding instantly.

Shut off the hot water supply before disconnecting or tapping into any hot water supply line.

NOTICE

Risk of property and equipment damage.

Water heating system can be damaged if water supply remains off.

Restore hot water supply as soon as humidifier installation is complete.

Water heating system must be de-energized if the main water supply remains shut off.

Do not set humidity level to or above the recommended level if condensation exists on inside windows of any unheated space. Condensate damage may result. Excess humidity can cause moisture accumulation which can allow the possibility for mold growth in the home.

Do not install humidifier in location where freezing temperatures may occur. The water line could freeze and crack, causing water damage to the home.

Do not connect the transformer to the multi-speed furnace blower motors or blower motors other than 120VAC.

Normal operating water pressure is 60 psi.

Do not install humidifier where water pressures exceed 125 psi. Humidifier damage may result. Follow applicable codes concerning pressure reduction.

Do not install power humidifier on supply or return plenum where static pressure exceeds 0.3" w.c.

Do not install humidifier on furnace cabinet.

Do not install humidifier on cooling coil cabinet or cooling coil plenum.

Do not operate heating or cooling system unless humidifier cover is installed.

TYPICAL APPLICATIONS

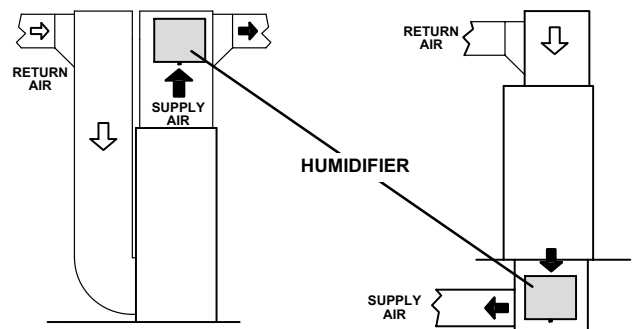

UPFLOW UNIT

DOWNFLOW UNIT

NOTE - Not for installation in horizontal supply ducts in horizontal applications.

WIRING DIAGRAM - HUMIDIFIER WITH MANUAL HUMIDISTAT*

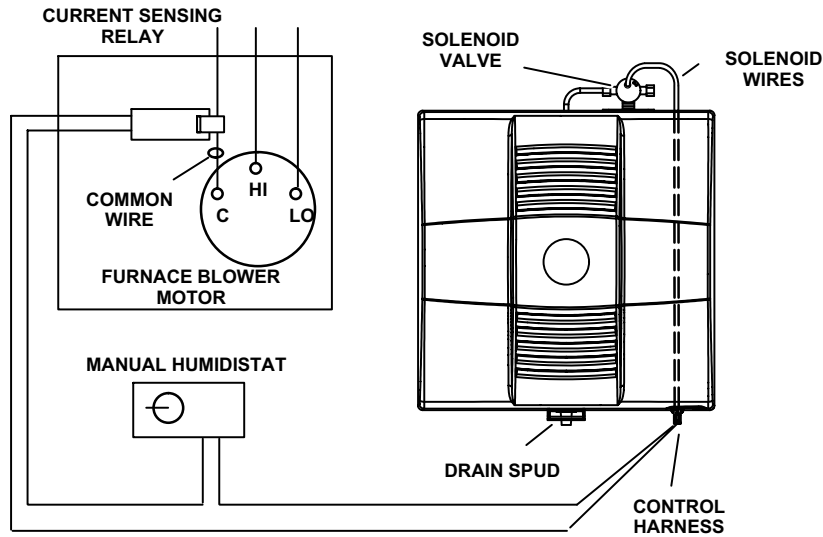

*See instructions provided with universal humidifier control for automatic control wiring.

WIRING DIAGRAM - HUMIDIFIER WITH COMFORTSENSE™ 7000 THERMOSTAT

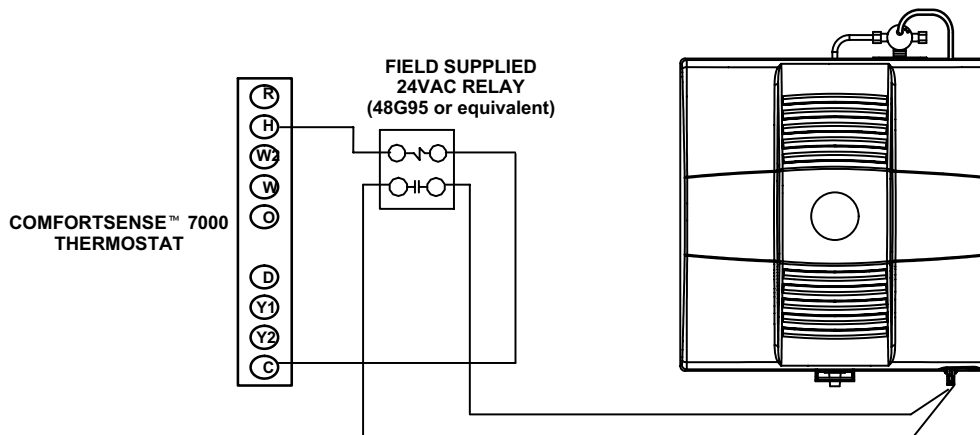

Installation

Humidifier Cabinet Installation

⚠ WARNING

Electric shock hazard.

Can cause injury or death.

Disconnect all electrical power supply to furnace before proceeding.

- 1 - This power humidifier is not recommended for installation on furnaces with horizontal air discharge. A bypass humidifier should be used in those applications. For all other forced air furnaces, the power humidifier is typically installed on the supply plenum. If installed on the return plenum, use hot water (140° F maximum) in the humidifier to provide a heat source for evaporation. Use a level and position

the provided template at least 1-1/2" above the furnace housing or cooling coil (if applicable) to provide clearance for the drain line. Trace around template edges and remove template.

- 2 - Accurately cut plenum along the traced edges. Take care to avoid cuts caused by sharp sheet metal edges.
- 3 - Use the following steps to open the humidifier assembly and remove the humidifier pad:
 - a - Pull the tab to release the motor control harness. Disconnect the harness.
 - b - Pull outward on the plastic snap handle on the bottom of the humidifier assembly to release the cover. Swing the cover open and then lift it away from the assembly.
 - c - Grasp the tabs on the humidifier pad frame and lift the pad out of the humidifier cabinet.

NOTE - It is sometimes easier to remove the frame by pulling on one tab at a time.

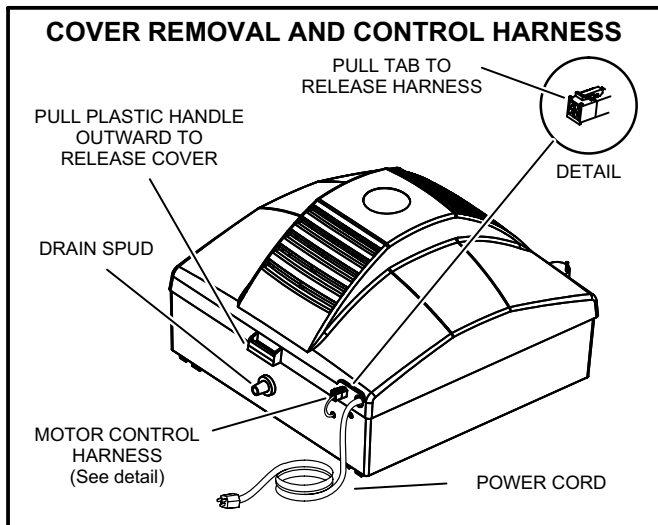

4 - Position the cabinet base with the two plastic engaging hooks pointing upward and the four hooks pointing downward. Engage the top two hooks along the top edge of the plenum opening. Push the base in and slide it downward to engage the bottom four hooks with the bottom edge of the plenum opening.

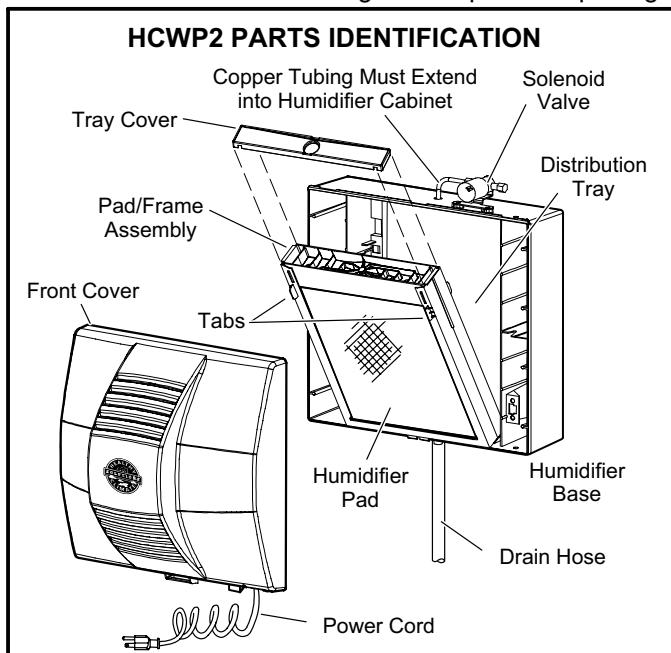

5 - Use the four provided #8 - 18 X 1-3/4" sheet metal screws to secure the humidifier base to the plenum. A screw hole is provided at each corner of the base. Additional screw holes are provided and may be used. Use foil tape or other preferred means to seal the joint between the humidifier and duct.

NOTE - Make sure that the surface of the plenum is flat. Use field-supplied gasket material between the plenum and the humidifier base if the plenum surface is uneven.

6 - Align the humidifier pad assembly drain with the drain in the cabinet base. Slide the pad assembly back into place. Make sure that the tray cover is firmly positioned inside the distribution tray.

7 - Insert the cover tabs into the slots at the top of the humidifier cabinet base. Close cover and press gently on the latch to make sure that cover is secure.

8 - Reconnect motor control harness. Make sure that harness snaps into position.

Humidistat Installation -- HCWP2-18 Units Only

A manual humidistat is provided with the HCWP2-18 to control the humidifier operation. Follow the instructions below to properly position, install and wire the humidistat with these units.

NOTE - For HCWP2-18A units, follow the instructions provided with the humidifier control (universal humidistat) shipped with the unit.

Locate the humidistat per the following recommendations:

- Position the humidistat either on an inside wall in the living area approximately 5 feet above the floor, or on the furnace return air plenum. An adapter plate is provided for return air plenum installation.
- Locate the humidistat out of the way of drafts caused by furnace discharge air, or drafts which may occur near open doors or windows.
- Locate the humidistat where it will not be affected by heat generated by lamps, sunlight, fireplace registers, radiators, concealed air ducts and pipes.
- Locate the humidistat where it will not be affected by activities that may generate moisture.

Wire the humidistat per the diagram on page 2. The following recommendations apply to the humidistat and its wiring connections:

- **Do not attempt to calibrate or repair this control.**
- The humidistat requires 24VAC power only. **Do not apply higher voltages to the control.**
- Check to ensure that wire insulation is not damaged and that no bare wire is exposed. Wire insulation should extend to the head of the binding screws.
- Splices must be secure.
- Use 18-gauge copper wire for runs up to 150 feet.
- If wiring may be exposed to UV light, wrap wires in foil tape to prevent damage to wire insulation.
- Remove any dirt or debris from the inside of the control using a fine, soft brush.

Power Wiring

120VAC power supply outlet must be provided near the humidifier. The outlet may be powered by 120VAC power from the furnace accessory terminals, if available. Do not use extension cords to provide power to the humidifier.

Water Supply

NOTICE

Before tapping into water supply, shut off water supply at the main valve. Open any faucet to relieve water pressure before proceeding.

Either cold or hot water which is either softened or unsoftened may be used as a water supply for the humidifier. Domestic hot water with a temperature **no higher than 140°F** along with continuous blower operation will provide maximum humidifier capacity.

- 1 - **Saddle Valve Installation** - Install the saddle valve using the appropriate method depending on the pipe material.

NOTE - The provided saddle valve should be fully opened or fully closed. It is not designed to regulate water flow.

Copper or Plastic Pipe

Use the following steps to install the provided saddle valve on copper or plastic pipe:

- a - Place a rubber gasket in the center of the hole in the top saddle clamp.
- b - Place both top and bottom clamps around the water pipe where the tap is to be made. Use bolts to tighten the clamps evenly. Do not overtighten the clamps.
- c - Screw the valve body into the opening in the top saddle clamp and tighten.
- d - Tighten the nut on the valve body.
- e - Install a 1/4" supply line to the humidifier using compression fittings.
- f - Turn the handle until the spindle is firmly seated into the valve body. This will pierce the water pipe. Turning the spindle in will shut the valve.

Steel or Brass Pipe

Use the following steps to install the provided saddle valve on steel or brass pipe.

NOTE - The water supply must be turned off and the pressure must be bled from the water line before drilling into brass or steel pipe.

- a - Drill a 3/16" diameter hole in the pipe where the tap will be located.
- b - Place a rubber gasket in the center of the hole in the top saddle clamp.
- c - Position the top clamp so that the spindle from the valve fits into the hole.
- d - Place both top and bottom clamps around the water pipe. Use bolts to tighten the clamps evenly. Do not overtighten the clamps.
- e - Screw the valve body into the opening in the top saddle clamp and tighten.
- f - Tighten the nut on the valve body.
- g - Install a 1/4" supply line to the humidifier using compression fittings.

NOTE - If the pipe is larger than 1" O.D., use 1/4"-20 X 1-3/4" bolts.

- 2 - Connect field-provided 1/4" copper tubing from the saddle valve to the inlet side of the solenoid valve. Use a **double wrench** technique to tighten the connection in order to prevent leaking and to avoid damage to the valve. Support the copper tubing, as necessary. Strain from the weight of the tubing can affect the solenoid assembly alignment.
- 3 - Check the copper tubing from the outlet side of the

solenoid valve to make sure that the tubing extends completely through the grommet and into the humidifier cabinet.

NOTE - Failure to properly install the copper tubing may result in a water leak outside of the humidifier cabinet.

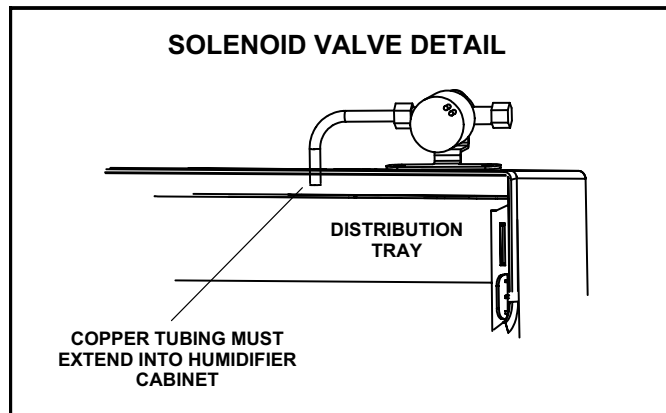

- 4 - Connect a field-provided 1/2" I.D. plastic hose from the humidifier drain stub to a floor drain. The drain line must have a continuous slope. Do not overtighten hose clamps which may be used to connect the drain line to the drain stub. Install a P-trap if backward pressure at the drain is possible.
NOTE - Drain and water supply piping must be protected from freezing temperatures, where applicable.
- 5 - Turn on water supply.

NOTICE

Do not sweat or attach a metal drain line to the drain stub on the humidifier.

Do not use a solvent-type adhesive when connecting a plastic drain hose.

Either practice could damage the drain line fitting.

Start-Up

- 1 - Open saddle valve completely.
- 2 - Turn on power to the furnace and initiate a heating demand.
- 3 - HCWP2-18 -- Adjust the humidistat setting so that the humidifier will turn on. Allow the humidifier to run until water can be seen coming out of the drain line. Check to make sure that system is watertight. Set humidistat to recommended level.
HCWP2-18A -- Check to make sure that system is watertight. Follow System Checkout procedures given in humidifier control (universal humidistat) instructions.