

READ COMPLETE SAFETY INSTRUCTIONS AND INSTALLATION TEMPLATE BEFORE STARTING INSTALLATION

ATTENTION INSTALLER:

This product must be installed by a qualified heating and air conditioning contractor. Failure to do so could result in serious injury from electrical shock.

This product must be installed in compliance with all local, state and federal codes.

Proper humidification and humidity control also requires that the home be constructed in accordance with local codes and good building practices.

Aprilaire® MODEL 400 SERIES HUMIDIFIER

WARNING

- ELECTRICAL SHOCK HAZARD.** Disconnect electrical power to the furnace before starting installation. Failure to do so could result in serious injury from electrical shock.
- SHARP EDGES HAZARD.** Sharp edges may cause serious injury from cuts. Use care when making plenum openings and handling ductwork.
- RISK OF SCALDING.** Water temperature over 125°F can cause severe burns and scald instantly. Shut off the hot water supply before disconnecting or tapping into any hot water supply line.

CAUTION

- RISK OF PROPERTY AND EQUIPMENT DAMAGE.**
- Do not install humidifier where freezing temperatures could occur. The water line could freeze and crack causing water damage to the home.
 - Do not install humidifier or bypass connection on the furnace jacket.
 - Do not install humidifier or bypass connection on a plenum face where the blanked off ends of the cooling coil will restrict air movement through the humidifier.
 - Do not set humidity level above recommended or to recommended level if condensation exists on inside windows of any unheated space, as condensation damage may result. Excess humidity can cause moisture accumulation which can allow the possibility for mold growth in the home.
 - Do not connect Model 400A or 400M transformer to blower motor wiring. Premature component failure may result.
 - When installing Humidifier Control on downflow furnace, ensure blower continues to run after a heat call is satisfied to eliminate high temperatures from damaging the Control.
 - Do not install humidifier where water pressure exceeds 125 psi, since damage to the humidifier may result. Follow codes in effect concerning pressure reduction.
 - Do not install humidifier on systems with greater than 0.4 in. wg pressure differential between supply and return plenums.

SPECIFICATIONS

- HUMIDIFIER DIMENSIONS
 Width (including solenoid valve): 15 3/8"
 Height (including drain spud): 15 3/4"
 Depth: 10 1/4"
- BYPASS DUCT OPENING
 6" diameter
- PLENUM OPENING
 10"W x 12 3/4"H
- ELECTRICAL DATA
 24 VAC-60 Hz, 0.5 AMP

RECOMMENDED WIRING DIAGRAM

(SEE STEP 7 ON BACK AND "HUMIDIFIER CONTROL SAFETY AND INSTALLATION INSTRUCTIONS" FOR DETAILED WIRING INSTRUCTIONS)

Model 400A DIGITAL HUMIDIFIER CONTROL

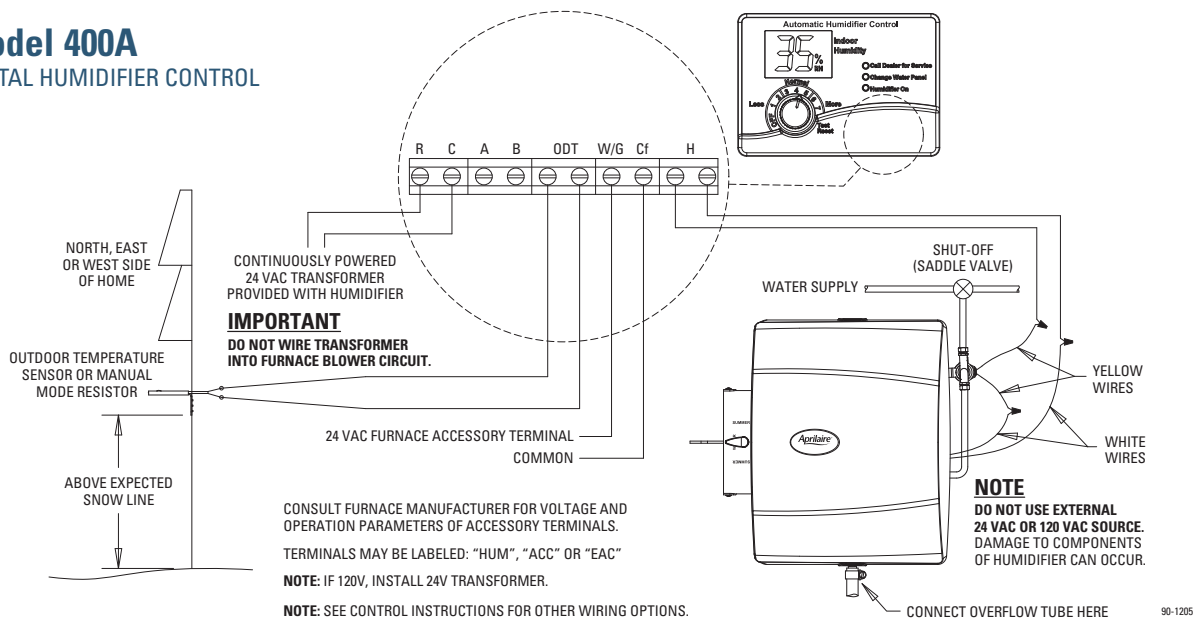

Model 400M MANUAL CONTROL

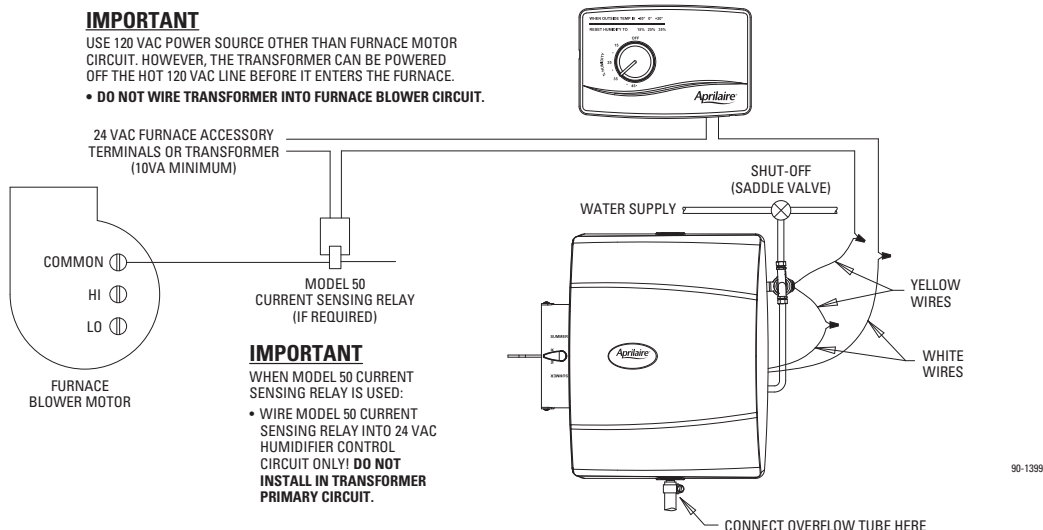

INSTALLATION OPTIONS

The Model 400A and 400M Aprilaire can be installed on either the supply or return plenum of a forced air handling system and is easily reversible for installation with right hand or left hand bypass duct connections. The humidifier dimensions and serviceability must be considered when selecting the best location for the humidifier. Here are 2 examples of many types of installations.

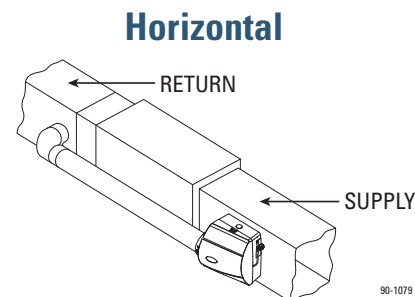
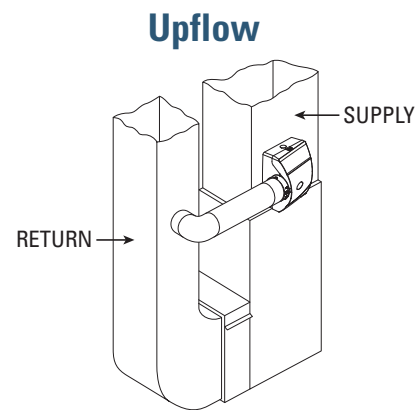

READ REVERSE SIDE FIRST!

- TOP -

READ REVERSE SIDE FIRST!

READ COMPLETE SAFETY INSTRUCTIONS AND INSTALLATION TEMPLATE BEFORE STARTING INSTALLATION

FURNISHED ITEMS
Built-in bypass damper
24 VAC Transformer
Digital Humidifier Control (Model 400A)
Manual Humidifier Control (Model 400M)
Humidifier Control Installation Instructions
Saddle valve
Humidifier Installation Template
ITEMS NOT FURNISHED
Mounting screws (sheet metal screws)
Water supply line (1/4" copper)
Drain line (1/2" I.D. hose)
Low voltage wire
Bypass ductwork
Model 50 Current Sensing Relay (if required)

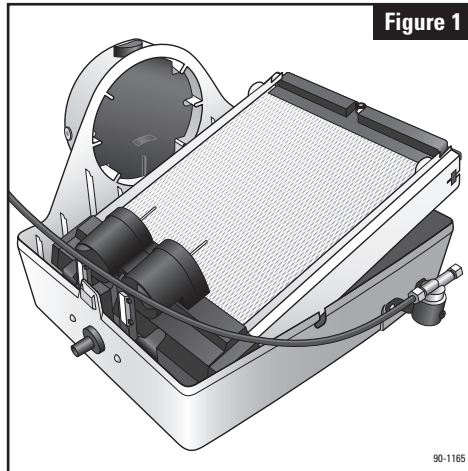

Figure 1

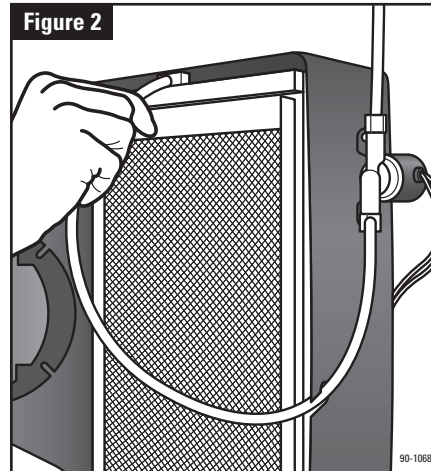

Figure 2

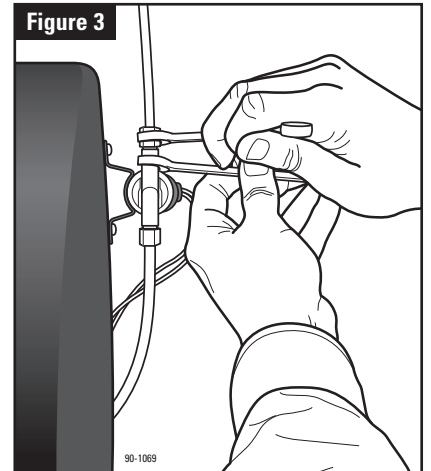

Figure 3

1. Press top & bottom tabs to remove cover (1). Pull feed tube (3) out of distribution tray (4). Remove Water Panel® Evaporator assembly. See **Figure 1**.

2. Humidifier is supplied with bypass duct connection on left. For right side bypass, swap location of water level sensor assembly (9) and cap (10).

3. Position template on supply or return plenum. Make sure template is level. Allow clearance for drain line and for servicing. Trace template outline. Cut 10" wide x 12-3/4" high opening. **Avoid injury from sharp edges.**

4. Place humidifier base (2) in opening and secure with 6 screws in openings provided.

5. Select location for 6" collar on opposite plenum to minimize length and number of elbows in bypass duct. Install 6" bypass duct components. Attach duct to humidifier collar using 2 screws in openings provided.

6. Insert Water Panel Evaporator assembly into base. Make sure bottom of scale control insert (6) is seated in water level sensor assembly (9). Snap top of evaporator assembly into base. Insert feed tube into distribution tray. See **Figure 2**. Make sure float cover (14) is snapped into place and that floats (13) move freely up and down. Rotate nameplate (11) if necessary, so it is right side up. Place point bypass damper handle (8) to "WINTER" (open) for heating season and "SUMMER" for cooling season.

7. Control installation and wiring. **Disconnect electrical power to furnace before wiring control.** In order for humidifier to operate, furnace must be on and RH must be below set-point of control. Wiring diagram illustrates recommended method of detecting furnace operation.

MANUAL HUMIDIFIER CONTROL, MODEL 400M:

Manual Control can be mounted in return duct or on wall in living space. Knob and cover must be removed to mount control. See wiring diagram for 24V control connections.

- For return duct mounting, position template at least 6" upstream of bypass duct connection or humidifier. **Avoid injury from sharp edges when cutting opening.** Make sure foam gasket is in place and secure control to duct using 2 screws in holes provided.

- For wall-mount, select location that will not be affected by drafts or heat sources. Remove and discard foam gasket and secure control to wall over wire access opening using screws & anchors provided.

DIGITAL HUMIDIFIER CONTROL, MODEL 400A:

- Select location for control on return duct at least 6" upstream of bypass duct connection or humidifier. Position template on duct and mark location of RH sensor opening. Drill 3/4" hole for sensor. Knob and cover must be removed to mount control. Place control on duct with RH sensor extending into duct opening. Make sure gasket is in place around sensor cage. Secure control to duct using 2 screws in openings provided.
- Control must be powered by a continuous 24 V source. See wiring diagrams on template and control instructions for 24 V control connections.

8. Humidifier will function with cold, softened or unsoftened water. Saddle valve provided may be used to tap into water supply. See installation instructions on saddle valve package. Saddle valve is designed to be fully opened or closed. Do not use to regulate flow.

9. Run 1/4" copper tubing from saddle valve to solenoid valve. **DOUBLE-WRENCH TO PREVENT LEAKING.** See **Figure 3**.

10. Run 1/2" I.D. hose from drain spud to floor drain. Make sure drain has constant downward slope and is not kinked. Do not over-tighten hose clamp onto drain spud. Do not use solvent adhesive on drain spud.

11. Check humidifier operation. Open saddle valve and turn control to highest setting. Turn on furnace. Make sure all electrical connections are secure and all plumbing connections are water-tight. Set control to proper setting.

PARTS LIST

- | | | |
|----------------------------|---------------------------------------|--------------------|
| 1. Front Cover | 6. Scale Control Insert/Float Chamber | 11. Nameplate |
| 2. Base | 7. Integral Damper | 12. Solenoid Valve |
| 3. Feed Tube | 8. Damper Handle | 13. Float |
| 4. Water Distribution Tray | 9. Water Level Sensor Assembly | 14. Float Cover |
| 5. Water Panel Evaporator | 10. Hole Plug | |

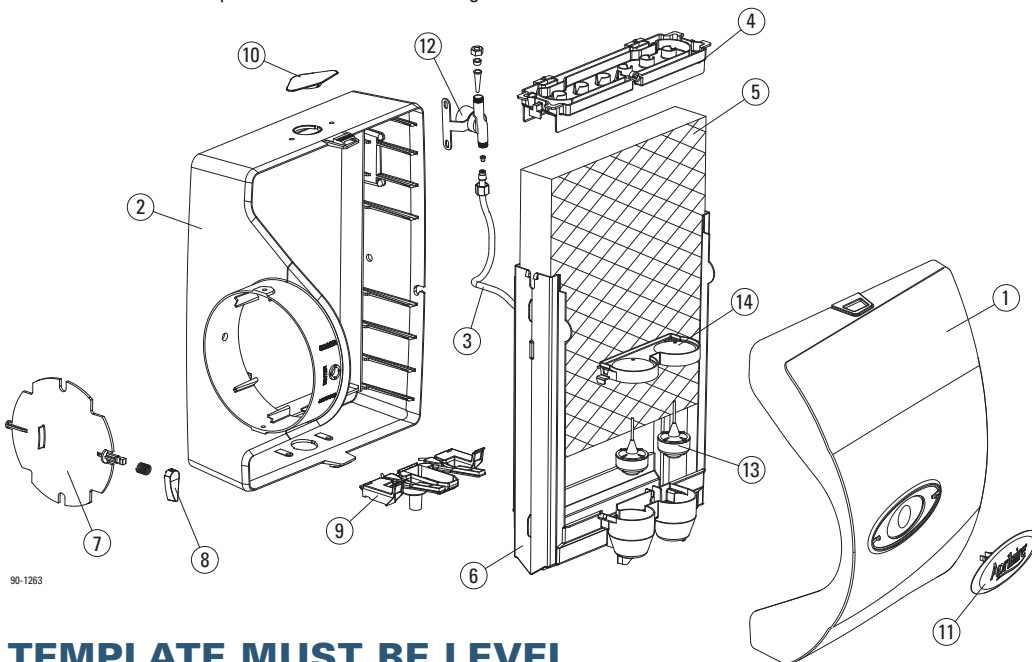

NOTE: BEFORE LEAVING THE JOB SITE, MAKE SURE:

1. Saddle valve is fully open.
2. All plumbing connections are watertight.
3. Humidifier functions properly.
4. Bypass damper is in proper position.

IMPORTANT! Be sure owner's manual containing instructions for operation and warranty information is given to owner in order to avoid unnecessary calls. Warranty is void unless humidifier is installed by qualified heating and air conditioning contractor due to possible misapplication of product.

TEMPLATE MUST BE LEVEL